

### Description

The HAO-1021/2 and HAO-1231-1234 Filter-Regulators combine the functions of a filter and pressure regulator into one compact, space saving unit for compressed air service in pneumatic control systems. The HAO-1021 and HAO-1022 are miniature models especially suited to application where space is limited or panel mounting is required.

The unit's pressure regulator function maintains accurate outlet pressure regardless of changes in inlet air pressure or downstream flow requirements. The non-rising, push-to-lock adjustment knob maintains the outlet pressure setting.

The unit's filtering section includes a large surface, 5 micron filter, designed to remove most solid and liquid particles from the compressed air.

Manual drain models utilize a finger-operated plunger (HAO-1021, 1022) or a 1/4-turn drain cock (HAO-1231, 1233). Automatic drain models (HAO-1232, 1234) activate when liquid accumulates in the filter bowl. Models equipped with a metal bowl, include a prismatic liquid level indicator.

### Features

- ◆ Non-rising, push-to-lock adjustment knob to ensure pressure settings
- ◆ Large surface, 5 micron filter
- ◆ Manual or automatic drain options
- ◆ Combined functions and convenient sizes provide application flexibility



Miniature

Standard

### Models

Refer to the specification table (reverse) to choose the appropriate model for your application.

HAO-1021	Miniature Regulator, 1/8" FPT
HAO-1022	Miniature Regulator, 1/4" FPT
HAO-1231	Standard Regulator, 1/4" FPT
HAO-1232	Standard Regulator, 1/4" FPT
HAO-1233	Standard Regulator, 3/8" FPT
HAO-1234	Standard Regulator, 3/8" FPT

### Accessories

HAO-1003	Panel Mounting Nut for models HAO-1021, 1022
HAO-1004	Wall Mounting Bracket & Nut for models HAO-1021, 1022
HAO-1023	Filter Elements (5 micron) for models HAO-1021, 1022
HAO-1015	Wall Mounting Bracket & Nut for models HAO-1231-1234
HAO-1016	Panel Mounting Nut for models HAO-1231-1234
HAO-1236	Filter Elements (5 micron) for models HAO-1231-1234

## Details

All Dimensions in Inches (mm)

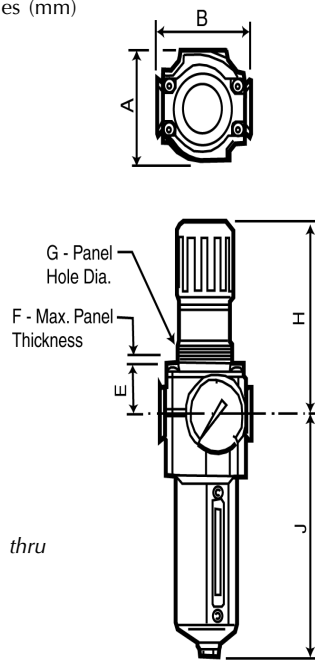

HAO-1021, 1022; HAO-1231 thru 1234 Filter Regulators

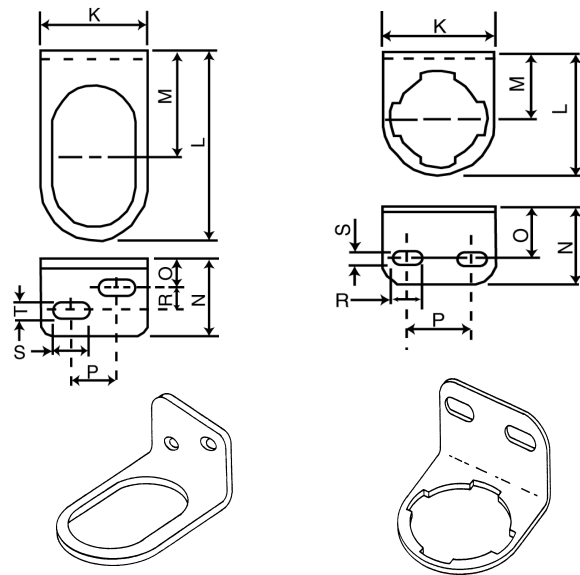

HAO- Wall Bracket

HAO-1015 Wall Bracket

Model	A (Max.Dia.)	B	E	F	G	H	J	
							AUTO DRAIN	MANUAL DRAIN
HAO-1021, 1022	1.50 (38)	1.63 (41)	1.12 (28)	0.25 (6)	1.19 (30)	2.67 (68)	-	3.77 (96)
HAO-1231-1234	2.45 (62)	2.68 (68)	1.22 (31)	0.25 (6)	1.89 (48)	3.80 (96)	5.80 (147)	6.15 (156)

Wall Bracket	K	L	M	N	O	P	R	S	T
HAO-1004	1.50 (38)	2.47 (63)	1.41 (36)	1.00 (25)	0.38 (10)	.069 (18)	0.31 (98)	0.51 (13)	0.22 (6)
HAO-1015	2.50 (64)	2.75 (70)	1.50 (38)	1.50 (38)	1.00 (25)	1.50 (38)	0.66 (17)	0.28 (7)	-

## Specifications

MODEL	HAO-1021	HAO-1022	HAO-1231	HAO-1232	HAO-1233	HAO-1234
<b>Main Port Size</b>	1/8" FPT		1/4" FPT		3/8" FPT	
<b>Filter Drain</b>	Manual		Manual	Automatic	Manual	Automatic
<b>Rated Flow <sup>A</sup></b>	11 scfm (312 L/s)	16 scfm (453 L/s)	70 scfm (1981 L/s)			
<b>Gauge Ports (2)</b>	1/8" FPT		1/4" FPT			
<b>Maximum Inlet Pressure</b>	150 psig (1034 kPa)		250 psig (1724 kPa)			
<b>Outlet Pressure Range <sup>B</sup></b>	5-100 psig (34-690 kPa)		5-150 psig (34-1034 kPa)	5-60 psig (34-414 kPa)	5-150 psig (34-1034 kPa)	5-60 psig (34-414 kPa)
<b>Operating Temperature Range <sup>C</sup></b>	0-125°F (52°C)		0-175°F (79°C)			
<b>Regulator Type</b>	Relieving diaphragm					
<b>Filter Element</b>	5 micron					
<b>Fluid</b>	Compressed air only					
<b>Materials</b>	Zinc body, Acetate bonnet, Brass valve, Nitrile elastomers, Polycarbonate bowl, Polypropylene filter element		Aluminum body, bonnet and bowl, Brass valve, Nitrile /Neoprene elastomers; Sintered Plastic Filter Element			

<sup>A</sup> Approximate flow at 100 psig (689 kPa) inlet pressure and 25 psig (172 kPa) outlet pressure.

<sup>B</sup> Outlet pressure can be adjusted to 0 psig; however a regulator should not be used to control outlet pressures less than the minimum setpoint

<sup>C</sup> Air supply must be dry enough to avoid ice formation at temperatures below 35° F (2°C)

**KMC Controls, Inc.**

19476 Industrial Drive

New Paris, IN 46553

574.831.5250

www.kmccontrols.com